

product description

TC4056A It is a complete single lithium-ion battery with a constant current / constant-voltage linear charger. Bottom finned ESOP8 with DIP8 Package, with low external component count of such TC4056A Ideal for portable applications. TC4056A You can fit USB Power adapter and power supply.

As a result of internal PMOSFET Architecture, coupled with anti-down charge circuit, so that no external blocking diode. Thermal feedback to automatically adjust the charging current to limit the die temperature during high power operation or high ambient temperature conditions. The charge voltage is fixed at 4.2V , The charge current can be set by an external resistor. When the charge current drops to the final value after reaching float voltage 1/10 Time, TC4056A The charge cycle is automatically terminated.

When the input voltage (AC adapter or USB Power) is removed when, TC4056A Automatically enters a low current state, the drain current to the battery 2uA the following. TC4056A When a power down mode can also be placed so as to supply current to 55uA . TC4056A Other features include a battery temperature detection, undervoltage lockout, automatic recharge and two for indicating the charging end led State pin.

Feature

- Up 1000mA Programmable charge current
- No need MOSFET , Sense resistor or blocking diode
- A single lithium-ion batteries, using SOP Complete Linear charger package
- Constant-current / constant-voltage operation, and having a charge rate can be achieved without risk maximize overheating thermal regulation
- Accuracy $\pm 1.5\%$ of 4.2V Predetermined charge voltage
- Current monitor for detecting the output of battery
- Automatic recharge
- Dual output state of charge, and fault-free battery status display
- C / 10 Charge termination
- Current supply in the standby mode 55uA
- 2.9V Trickle Charge version
- Soft-start limits inrush current
- Battery temperature monitoring function
- use 8 Pin package (ESOP-8 , DIP-8)

Applications

- mobile phone, PDA
- MP3 , MP4 player
- Digital cameras
- E-dictionary
- GPS
- Portable equipment, various chargers

Absolute Maximum Ratings

- Input supply voltage (Vcc) : - 0.3V ~ 8V
- PROG : - 0.3V ~ Vcc + 0.3V
- BAT : - 0.3V ~ 7V
- GHRG : - 0.3V ~ 10V
- STDBY : - 0.3V ~ 7V
- TEMP : - 0.3V ~ 7V
- CE : - 0.3V ~ 7V
- BAT Short circuit duration: Continuous
- BAT Pin Current: 1200mA
- PROG Pin Current: 1200uA
- The maximum junction temperature: 145 °C
- Operating temperature range: - 40 °C ~ 85 °C
- Storage temperature range: - 65 °C ~ 125 °C
- Lead Temperature (Soldering 10 second): 260 °C

Complete charging cycle (1000mAh battery)

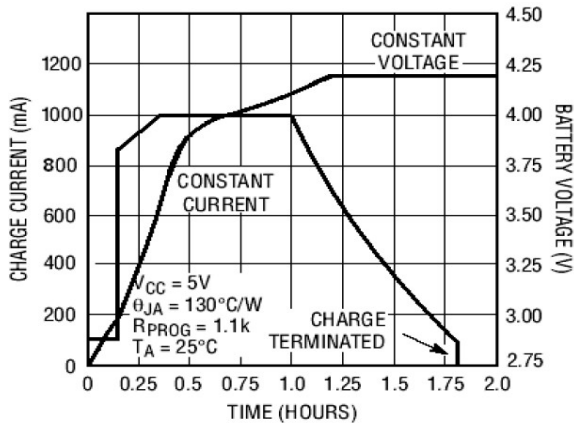

Package / Ordering information and functions

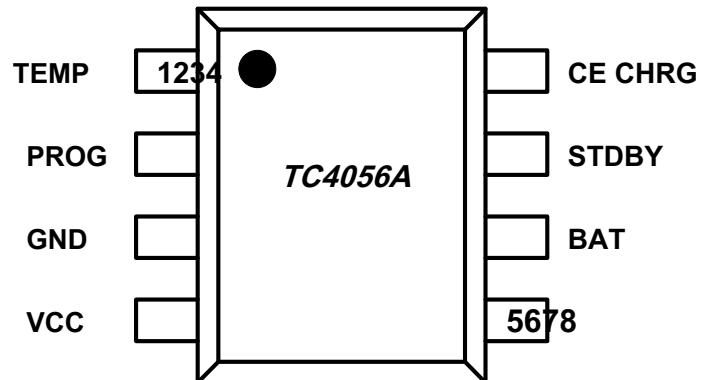

TEMP (Pins 1): Battery temperature detection input terminal. will TEMP Pin to current NTC The output of the sensor. in case TEMP Pin voltage less than the input voltage 45% Or greater than the input voltage 80% It means that the battery temperature is too low or too high, the charging is suspended. in case TEMP

Direct access GND Battery temperature detection function is canceled, another charging function properly.

PROG (Pins 2): Constant charge current and a charge current monitoring terminal is provided. From PROG Pin is connected to the ground terminal of an external resistor can be programmed charging current. In the precharge phase, the voltage at this pin is modulated 0.1V ; Constant-current charging phase, the voltage at this pin is fixed 1V . In all modes, the state of charge, measuring the voltage at pin charging current can be estimated according to the following formula:

$$I_{BAT} = \frac{V_{PROG}}{R_{PROG}} \times 1200$$

GND (Pins 3): Power ground.

VCC (Pins 4): Input voltage at the positive input terminal. This voltage is the power supply pin of the internal circuit. when Vcc versus BAT Is smaller than the voltage difference between pins 30mV Time, TC4056A Enters low power shutdown modes, then BAT Pin current is less than 2uA .

BAT (Pins 5): A battery connection terminal. The positive terminal of the battery is connected to this pin. In the chip disable mode or in sleep mode, BAT Pin leakage current is less than 2uA . BAT Pin provides charge current to the battery, and 4.2V Limit voltage.

STDBY (Pins 6): Indicating completion of charging the battery terminal. When the current charging is completed STDBY Internal switch is pulled low to indicate the completion of charging. In addition, STDBY The pin is in high impedance state.

CHRG (Pins 7) The state of charge indication open-drain output terminal. When the battery is being charged, CHRG Internal switch pin is pulled low, indicating the charging progress; otherwise CHRG Pin is high impedance.

CE (Pins 8) Chips before they can input. High input level will TC4056A In normal working condition; low input level so TC4056A It is prohibited in the state of charge. CE Pin can be TTL Level or CMOS Level driver.

Electrical characteristics (Where Table Notes • It denotes specifications which apply over the full operating temperature range, otherwise specifications TA = 25 °C, Vcc = 5V Unless otherwise noted.)

symbol	parameter	condition		Min	Typ	Max	Units			
VCC	Input supply voltage		•	4.0	5	8.0	V			
ICC	Input supply current	Charging mode, R _{PROG} = 1.2K	•			150	550	μA		
		Standby mode (charge termination) Stop mode (R _{PROG} not connected, VCC < VBAT ,or VCC < VUV)	•			100		μA		
			•			100		μA		
			•			100		μA		
VFLOAT	Stable output (floating) voltage	0 °C ≤ TA ≤ 85 °C,		4.16	4.2	4.24	V			
IBAT	BAT Pin Current: (Current mode test conditions VBAT = 4.0V)	R _{PROG} = 2.4K The current mode	•	450		500	550	mA		
		R _{PROG} = 1.2K The current mode		900	1000	1050		mA		
		Standby mode, VBAT = 4.2V	•	0		- 2.5 - 6		μA		
		Shutdown Mode (R _{PROG} Not connected) sleep Sleep mode, VCC = 0V	•	0		2	40	μA		
			•	0		- 2	μA			
I _{TRIKL}	Trickle charge current	V _{BAT} < V _{TRIKL} , R _{PROG} = 1.2K	•	120		130	140	mA		
V _{TRIKL}	Trickle charge threshold voltage	R _{PROG} = 1.2K , VBAT rise		2.8	2.9	3.0	V			
V _{TRHYS}	Trickle charge voltage hysteresis	R _{PROG} = 1.2K		60	80	100	mV			
V _{UV}	VCC Undervoltage lockout threshold	From VCC Low to High	•	3.5	3.7	3.9	V			
V _{UVHYS}	VCC Undervoltage lockout hysteresis		•	150		200	300	mV		
V _{ASD}	VCC-VBAT Lockout threshold Press	VCC From low to high		605		10030	10030	mV		
		VCC High to Low						mV		
I _{TERM}	C / 10 Termination current threshold	R _{PROG} = 2.4K R _{PROG} = 1.2K	•			70	130	80	140	mA
			•	60	120					mA
V _{PROG}	PROG Pin voltage	R _{PROG} = 1.2K The current mode	•	0.9		1.0	1.1	V		
V _{CHRG}	CHRG Low voltage output pin	I _{CHRG} = 5mA				0.3	0.6	V		
V _{STDBY}	STDBY Pin output low level	I _{STDBY} = 5mA				0.3	0.6	V		
V _{TEMP-H}	TEMP Pin high-end flip Voltage					80	82	% V _{CC}		
V _{TEMP-L}	TEMP Pin low-end flip Voltage			43	45			% V _{CC}		
ΔV _{RECHRG}	Threshold voltage of the rechargeable battery	V _{FLOAT} - V _{RECHRG}		100	150	200		mV		
T _{LIM}	Defining a temperature model of the junction temperature					145		°C		
R _{ON}	power FET " Conduction " Resistance (in VCC versus BAT between)					650		mΩ		
t _{ss}	Soft start time	IBAT = 0 to IBAT = 1200V / R _{PROG}				20	4	μs		
t _{RECHARGE}	Filter Time recharge	VBAT High to Low		0.8	1.8	4		ms		
t _{TERM}	Termination Comparator Filter Time	IBAT Drops I _{CHG} / 10 the following		0.8	1.8			ms		
I _{PROG}	PROG Pin pull-up current					2.0		μA		

Typical Performance Characteristics

Constant current mode PROG Pin

The voltage versus supply voltage

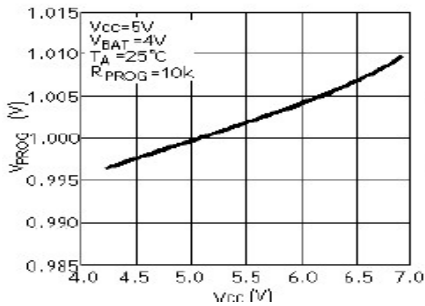

Stable output (float) and the charging voltage

Electric current curve

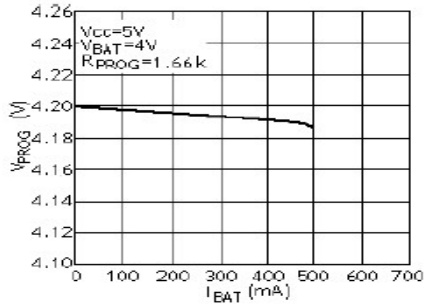

Curve trickle charge threshold and temperature Charging current and the battery voltage curve

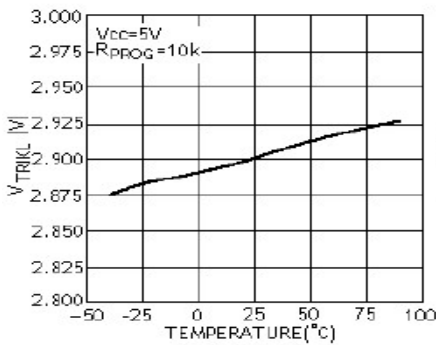

PROG Pin voltage and temperature

Relationship lines

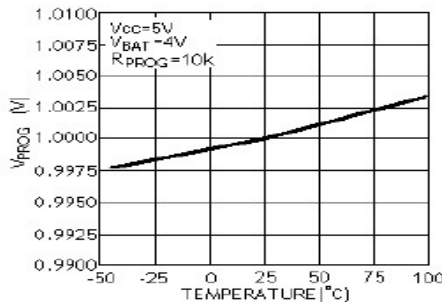

Stable output (Float) Voltage Temperature

The degree of curve

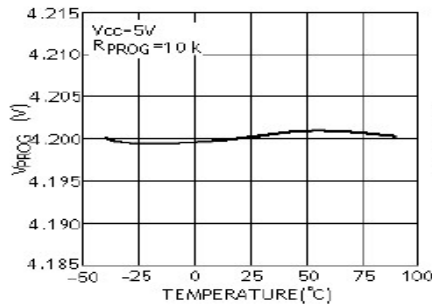

And a charging current PROG Pin

Pressure curve

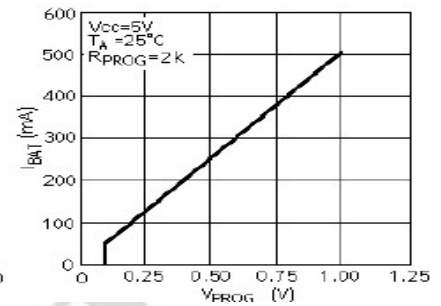

Stable output (float) the voltage indicating

Pressure curve

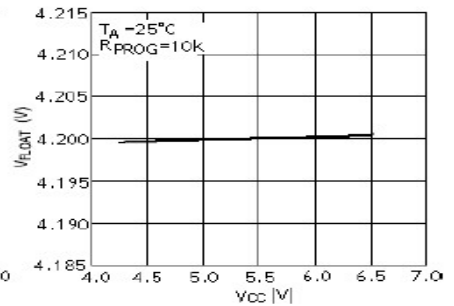

The charge current curve of the supply voltage

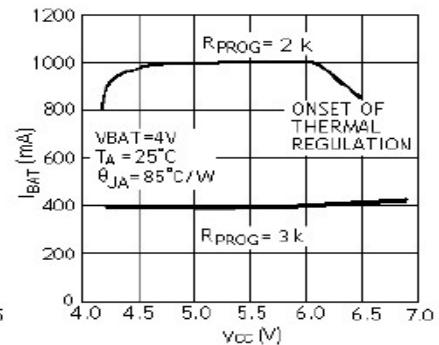

Ambient temperature and the charging current curve Curve rechargeable power threshold voltage and temperature FET * Conduction * Resistance versus temperature

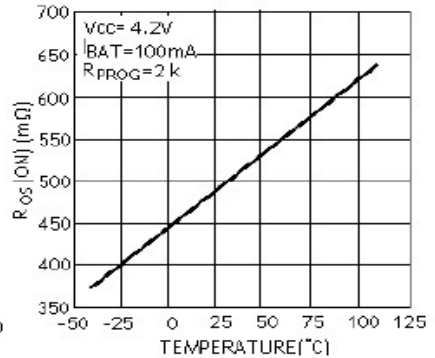
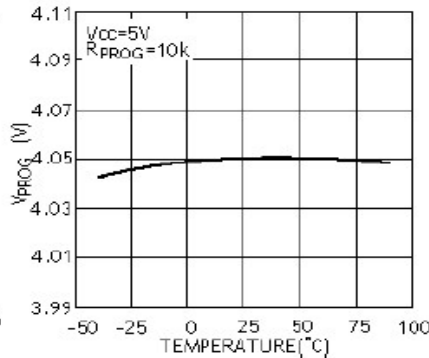
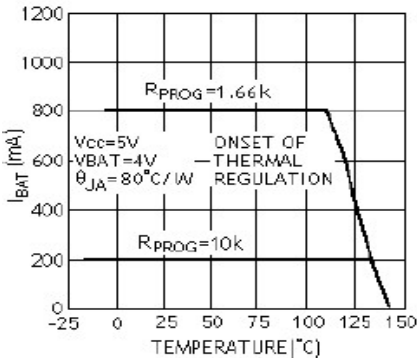

Block diagram and working principle

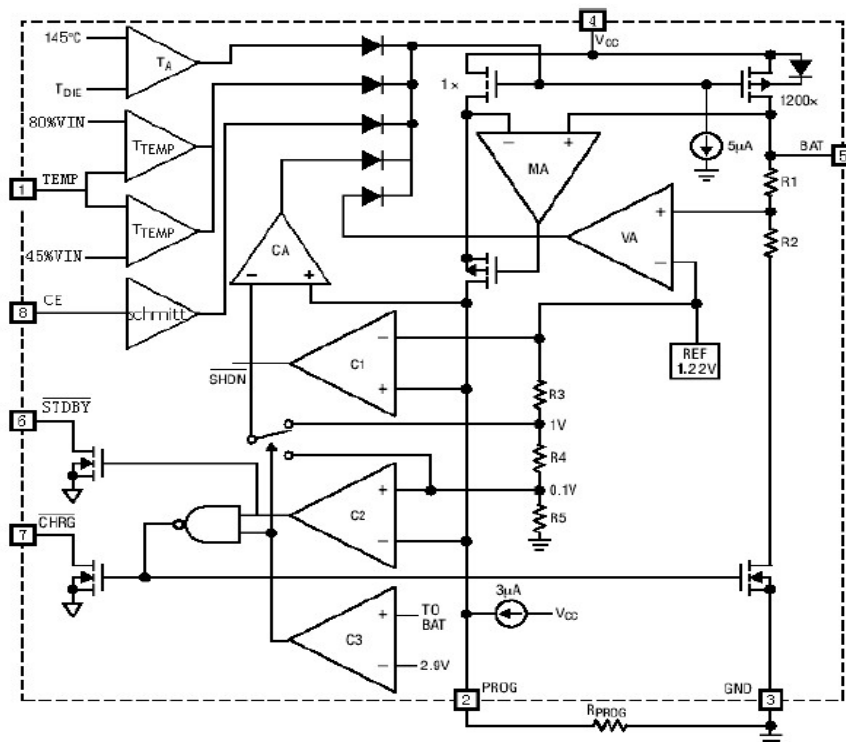

TC4056A Linear charger circuit is designed for a lithium ion or lithium polymer battery is designed, using a chip inside the power transistor for a constant current and constant voltage battery charge. The charging current can be programmed with an external resistor, the charging current up to the maximum continuous 1A No blocking diode and current sense resistor. TC4056A Contains two open-drain output state indication output terminal, the charging indicator status CHRG Fault Status and output terminal STDBY . Power management circuitry inside the chip junction temperature of the chip exceeds 145 Automatically reduces the charge current °C, this feature allows the user to use the maximum power handling capability of the chip, do not worry about damaging the chip or the chip overheating external components. Thus, when the charge current user may not consider the worst case, but only according to typical case can be, as in the worst case, TC4056A It will automatically reduce the charging current.

When the input voltage is greater than the supply voltage detection threshold and the low chip enable input pull high, TC4056A Start charging the battery, CHRG Output pin low to indicate that charging is in progress. If the battery voltage is below 3V , The battery charger is precharged with a small current. When the battery voltage exceeds 3V , The battery charger uses a constant current mode, the charging current from the PROG Pin and GND Resistance between R_{PROG} determine. When the battery voltage is close to 4.2V Voltage, the charging current decreases, TC4056A Constant voltage charging mode. When the charge current is reduced to a charge termination threshold, of a charge cycle, CHRG End a high impedance state, STDBY The low potential side.

Charge end threshold is a constant charge current 10% . When the battery voltage falls below the recharge threshold, a new charge cycle starts automatically. Precision voltage reference source within the chip, the error amplifier and the resistor divider network to ensure the accuracy of the battery voltage in the modulator 1.5% Or less, meet the requirements of a lithium ion battery and lithium polymer batteries. When the power-down the input voltage or the input voltage is lower than the battery voltage, the charger enters a low power sleep mode, the current consumption of the battery is less than the end 3uA From an increase of standby time. If you enable input CE Then low, the charger to stop charging.

The charging current is set

A charging current is connected to the color PROG A resistor between the pin and ground to set. And a charging current setting resistor is calculated using the following equation: to determine the resistance of the charging current according to the resistance required

$$R_{PROG} = \frac{1200}{I_{BAT}} \quad (\text{误差} \pm 10\%)$$

Customer applications, according to need Seeking select the appropriate size R_{PROG} . R_{PROG} Determining the relationship between the charging current is shown in the table :

R_{PROG} (K)	I_{BAT} (M A)
30	50
20	70
10	130
5	250
4	300
3	400
2	580
1 . 66	690
1 . 5	780
1 . 33	900
1 . 2	1000

Charge termination

When the current reaches the final float charging voltage drops below a set value 1/10 When the charge cycle is terminated. This condition is achieved by using an internal filtered comparator PROG Temporary control pins to detect. when PROG Pin voltage falls 100 m V For longer than t_{TERM} (Usually 1.8ms), The charge is terminated. The charging current is latched off, TC4056A Enters standby mode, the input supply current is reduced to 55UA . (Note: C / 10 Failure to terminate and thermal limit trickle charge mode).

Charging, BAT Transient loads can cause the pin PROG Pin voltage DC Value of the charge current drops 1/10 Briefly fell between 100mV the following. Termination of the comparator 1.8ms Filter time ($TERM t$) To ensure that transient loads of this nature do not lead to premature termination of the charging cycle. Once the average value of the charge current drops 1/10 the following, TC4056A That terminates the charge cycle and stopped by BAT Pin any current. In this state, BAT All the load on the pins must be powered by a battery. In standby mode, TC4056A Correct BAT Pin voltage is continuously monitored. If this voltage drops 4.05V Recharging limit switches ($RECHRG V$) Hereinafter, another charge cycle begins again and the current supplied to the battery. Map 1 It shows a typical charge cycle state of FIG.

Charging status indicator

TC4056A Two open-drain status output terminal, CHRG with STDBY . When the charger is in the charging state, CHRG It is pulled low, in other states, CHRG In a high impedance state. When the outside temperature of the battery is in a normal temperature range, CHRG with STDBY Pins are high impedance. when TEMP When using typical connection end, When the battery charger is not received, indicates a fault condition: not lit in red and green TEMP Termination GND When the battery temperature detection does not work when there is no battery to the charger, CHRG Output pulse signal indicate that the battery. When the battery connecting terminal BAT Pin external capacitance 10uF Time CHRG Flashing frequency of about 1-4 Second indication state when not, will not have the status outputs to ground.

charging	red light CHRG Green	STDBY
Charging status	bright	Destroy
Full voltage state	Destroy	bright
<u>Voltage, battery temperature is too high, too low a fault condition, the battery without intervention or (TEMP use)</u>	Destroy	Destroy
BAT Termination 10u Capacitor, no battery (TEMP = GND)	Green light, red light flashes T = 1-4S	

Various state of charge indicating Refer TC4056A Cautions and DEMO Plate specification.

Thermal limitations

If the chip temperature is raised to about 140 °C than a preset value, then a thermal feedback loop reduces the internal charge current until 150 Reducing the current to the above °C 0 . This feature prevents TC4056A Overheated, and allows the user given increasing the maximum power handling capability of the circuit board without damage TC4056A risks of. In ensuring the charger will automatically reduce the current in the worst case conditions of the premise, according to a typical (but not the worst case) the ambient temperature is set to the charging current.

Battery temperature monitoring

In order to prevent the temperature is too high or too low for damage caused by the battery, TC4056A Battery temperature monitoring within the integrated circuit. It was monitored by measuring the battery temperature TEMP Voltage pin to achieve, TEMP Voltage pin is inside the cell NTC A thermistor and a resistor divider network of FIG. 1 Fig.

TC4056A will TEMP Internal chip pin with two voltage thresholds VLOW with VHIGH Compared to confirm that the temperature of the battery exceeds a normal range. in TC4056A internal, VLOW Is fixed $45\% \times V_{cc}$, VHIGH Is fixed $80\% \times V_{cc}$. in case TEMP Voltage pin VTEMP <VLOW or VTEMP> VHIGH , It indicates that the battery temperature is too high or too low, the charging process is suspended; if TEMP Voltage pin VTEMP in VLOW with VHIGH Among the charge cycle continues.

If the TEMP Pin to ground, the battery temperature monitoring function is disabled.

determine R1 with R2 The value

R1 with R2 Values to be determined according to the resistance value of the thermistor temperature monitoring range and a battery, are illustrated as follows: Assume the battery temperature range $T_L \sim T_H$,(among them $T_L < T_H$) ; Battery using a negative temperature coefficient thermistor (NTC), R_{TL} In its temperature T_L When the resistance, R_{TH} In its temperature T_H When the resistance of the $R_{TL} > R_{TH}$ Then, the temperature T_L When the first pin TEMP Voltage terminal is:

$$V_{TEMP_L} = \frac{R_2 \parallel R_{TL}}{R_1 + R_2 \parallel R_{TL}} \times V_{IN}$$

In the temperature T_H When the first pin TEMP Voltage terminal is:

$$V_{TEMP_H} = \frac{R_2 \parallel R_{TH}}{R_1 + R_2 \parallel R_{TH}} \times V_{IN}$$

Then, by the $V_{TEMP_L} = V_{HIGH} = k_2 \times V_{cc}$ ($k_2 = 0.8$)

$V_{TEMP_H} = V_{LOW} = k_1 \times V_{cc}$ ($k_1 = 0.45$)

We can solve for:

$$R1 = \frac{R_{TL}R_{TH}(K_2 - K_1)}{(R_{TL} - R_{TH})K_1K_2}$$

$$R2 = \frac{R_{TL}R_{TH}(K_2 - K_1)}{R_{TL}(K_1 - K_1K_2) - R_{TH}(K_2 - K_1K_2)}$$

Similarly, if the internal battery is a positive temperature coefficient (PTC) Thermistor, is>, we can calculate:

$$R1 = \frac{R_{TL}R_{TH}(K_2 - K_1)}{(R_{TH} - R_{TL})K_1K_2}$$

$$R2 = \frac{R_{TL}R_{TH}(K_2 - K_1)}{R_{TH}(K_1 - K_1K_2) - R_{TL}(K_2 - K_1K_2)}$$

As can be seen from the above derivation, to be set in a temperature range supply voltage Vcc It is irrelevant, and only R1 , R2 , RTH , RTL About; which,

RTH , RTL Can be found in related battery handbook or deduced from testing. In practice, if only one side of the temperature characteristic of interest, such as thermal protection, the R2 Can not, but only R1 It can be. R1 Derivation becomes simple, not discussed here.

Undervoltage lockout

An internal undervoltage lockout circuit monitors the input voltage, and Vcc It rises above the undervoltage lockout threshold before the charger in shutdown mode.

UVLO Charger circuit will remain in shutdown mode. in case UVLO The comparator transition occurs at Vcc Raised higher than the battery voltage 100mV Before charger will not exit the shutdown mode.

Manual Shutdown

Any point in the charge cycle can be set by CE A low potential side or removed R_{PROG} (So that PROG Pin floating) to the TC4056A Put into shutdown mode. This reduces the battery drain current to 2µA Or less, and the supply current drops 55µA the following. Re CE Opposite end connected to a high potential or a resistor may be set to start a new charging cycle. in case TC4056A It is in undervoltage lockout mode, CHRG And pins are high impedance state: either Vcc Higher BAT Pin voltage is less than the magnitude 100mV Or applied in Vcc Insufficient voltage on the pin.

Automatic restart

Once the charge cycle is terminated, TC4056A Now has adopted a 1.8ms Filter time (t_{RECHARGE}) Of the comparators BAT Continuously monitoring the voltage on the pin. When the battery voltage drops 4.05V (Substantially corresponding to the battery capacity 80 % to 90 %) Or less, the charge cycle begins again. This ensures that the battery needs to be maintained at (or near) a fully charged state, and eliminates the periodic charge cycle starts. In the recharge cycle, CHRG Output pin enters a strong pull-down state.

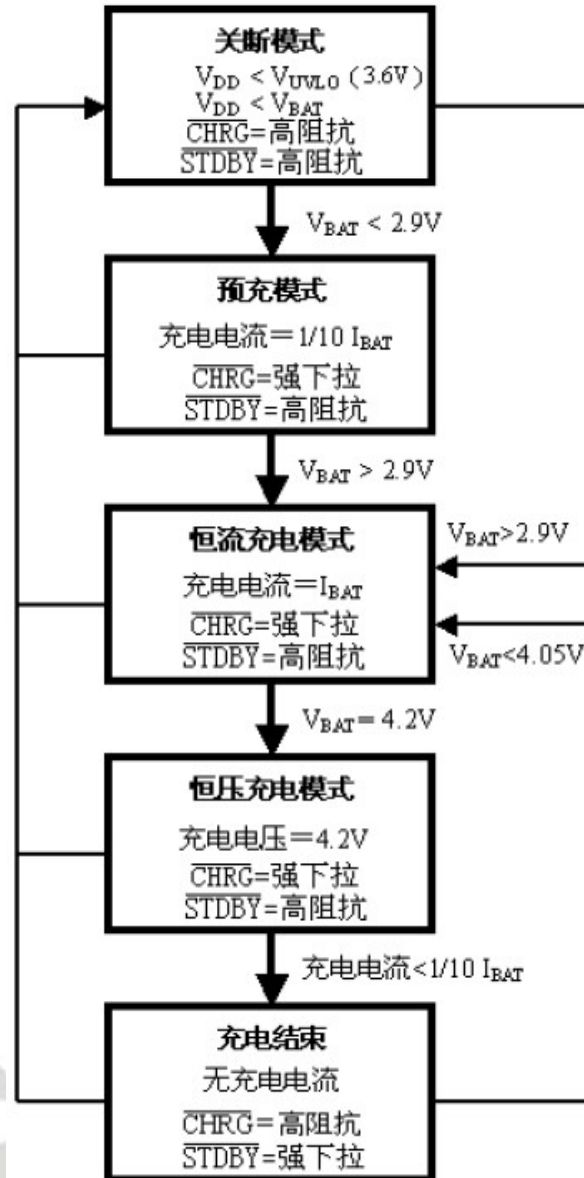

Map 1 : A typical charge cycle state of FIG.

Stability considerations

In the constant current mode, it is located in the feedback loop PROG Pins, instead of the battery. Stability constant current mode by PROG The effects of pin impedance. when PROG No additional capacitance will reduce the maximum allowable setting resistor the resistance of the pin. PROG Pole frequency should be kept on the pin CPROG , Can be calculated using the formula R_{PROG} The maximum resistance value:

$$R_{PROG} \leq \frac{1}{2\pi \cdot 10^5 \cdot C_{PROG}}$$

For users, they are more likely to be interested in the charging current, rather than the transient current. For example, if a run at low current mode switching power supply in parallel with the battery, from BAT The average current out of the pin is usually more important than the transient current pulses. In this case, it can be PROG Using a simple pin RC Filter to measure the average battery current (FIG. 2 Shown). in PROG The addition of a capacitor between the pin and the filter 10k Resistor to ensure stability.

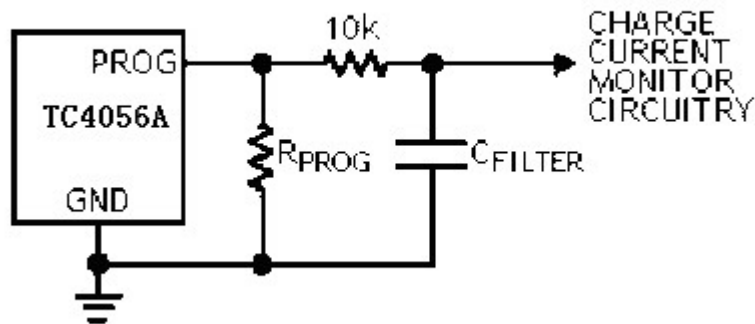

Map 2 : Isolation PROG Capacitive load on the pin and the filter circuit

Power loss

TC4056A Conditions for the sake of thermal feedback charging current is reduced by IC The estimated power loss. Nearly all of this power loss by the internal MOSFET produced - This approximation is obtained by the following formula:

$$P_D = (V_{CC} - V_{BAT}) \cdot I_{BAT}$$

Formula PD For the dissipation of power, VCC Input power source voltage, VBAT Battery voltage, IBAT Charging current. When the thermal feedback begins IC Providing protection, the ambient temperature is approximately:

$$T_A = 145^\circ C - P_D \theta_{JA}$$

$$T_A = 145^\circ C - (V_{CC} - V_{BAT}) \cdot I_{BAT} \cdot \theta_{JA}$$

Example: by programming from a 5V Power supply to get work TC4056A To have a 3.75V Discharge voltage lithium-ion battery to provide

800mA Full magnitude of the current. Hypothesis JA q for 150 °C / W (See board layout considerations), when TC4056A When the charging current begins to decrease, the ambient temperature is approximately:

$$T_A = 145^\circ C - (5V - 3.75V) \cdot (800mA) \cdot 150^\circ C / W$$

$$T_A = 145^\circ C - 0.5W \cdot 150^\circ C / W = 145^\circ C - 75^\circ C$$

$$T_A = 65^\circ C$$

TC4056A Can 65 Using at least °C ambient temperature conditions will be reduced but the charge current 800mA the following. For a given ambient temperature, the charging current may have determined the approximate formula:

$$I_{BAT} = \frac{145^\circ C - T_A}{(V_{CC} - V_{BAT}) \cdot \theta_{JA}}$$

As part of the operation principle discussed above, when the thermal feedback reduces the charge current, the PROG The voltage on the pin is also reduced proportionally.

Remember do not need TC4056A The worst heat conditions considered in the design application, which is very important, because the IC Will reach the junction temperature 145 Automatically reduces power consumption approximately deg.] C.

Thermal Considerations

due to SOP8 / MSOP8 The small form factor package, therefore, a need for using sophisticated thermal design PC Plate layout to maximize the available charge current may be used, it is very important. For dissipate IC Cooling path of the generated heat from the chip to the lead frame, and through the heat sink reaches a bottom PC Board copper. PC Board copper heat sink. Copper area connected to the heat sink should be as wide, and extends outwardly to a large copper area to spread the heat to the surroundings. Back to the inside or through-holes in the copper layers to improve the overall thermal performance of the charger are also quite useful. When performing PC Board layout design, other heat sources related to the charger board also must be considered, because they will affect overall temperature rise and the maximum charge current has been affected.

Increased thermal regulation current

Reduce the internal MOSFET The voltage drop across can be significantly reduced IC In power consumption. During thermal conditioning, which has an increased current supply to the battery effect. One countermeasure is through an external element (e.g. a resistor or a diode) will be part of the power dissipated. Example: by programming from a 5V AC power adapter to get work TC4056A To have a 3.75V Voltage of the lithium ion battery to discharge

800mA The full-scale charge current. Hypothesis $J_A \theta$ for $125^\circ\text{C}/\text{W}$, Then 25°C ambient temperature conditions, the charging current is approximately:

$$I_{BAT} = \frac{145^\circ\text{C} - 25^\circ\text{C}}{(5\text{V} - 3.75\text{V}) \cdot 125^\circ\text{C}/\text{W}} = 768\text{mA}$$

And by reducing a 5V Voltage of the resistor connected in series across the AC adapter (FIG. 3 Shown), the on-chip power consumption can be reduced, thereby increasing the thermal regulation of the charging current:

$$I_{BAT} = \frac{145^\circ\text{C} - 25^\circ\text{C}}{(V_S - I_{BAT}R_{CC} - V_{BAT}) \cdot \theta_{JA}}$$

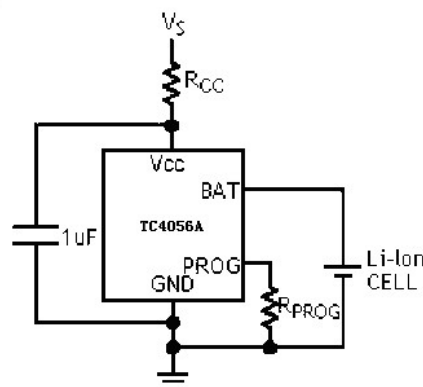

Map 3 : One kind of the thermal conditioning circuit pattern maximize the charge current section

Can be obtained using the quadratic equation 2

$$I_{BAT} = \frac{(V_S - V_{BAT}) - \sqrt{(V_S - V_{BAT})^2 - \frac{4R_{CC}(145^\circ C - T_A)}{\theta_{JA}}}}{2R_{CC}}$$

take $R_{CC} = 0.25\Omega$, $V_S = 5V$, $V_{BAT} = 3.75V$, $T_A = 25^\circ C$ and $125^\circ C / W$ θ_{JA} , We can calculate the thermal regulation of the charging current:

$I_{BAT} = 948mA$, The results described structure may be output at higher ambient temperatures 800mA Full-scale charge. Although this application may be delivered in thermal mode and more energy to the battery charging time is shortened, but in the voltage mode, if V_{CC} Becomes sufficiently low so that TC4056A State at a low pressure drop, it may actually lengthen the charging time. Map 4 It shows how this circuit with R_{CC} Increases caused by voltage drop. When the element size in order to maintain a small pressure drop and to avoid the R_{CC} Value is minimized, the best technology can play a role. Remember select a resistor having a sufficient power handling capability.

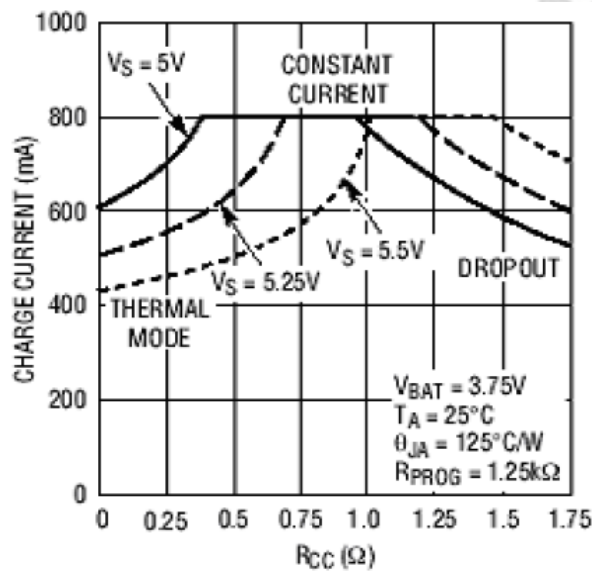

Map 4 : Charge current R_{CC} The curve

VCC Bypass capacitor

Various types can be input bypass capacitor. However, care must be taken when using multilayer ceramic capacitors. Because some types of ceramic capacitors having a high self-resonant Q Characteristic values, therefore, under certain start conditions (such as the battery charger is connected to the power supply input and a work) may produce a high voltage transients. And increase a X5R Ceramic capacitors in series 1.5Ω Resistor will minimize start-up voltage transients.

Charging current soft start

TC4056A Comprising a charging cycle for the start soft-start circuit to minimize the inrush current. When a charge cycle is initiated, the charging current 20μs Around time from 0 Up to full-scale full-scale value. During startup, it can play a role in minimizing the transient current load on the power supply.

Reverse polarity input voltage protection

In some applications, it is necessary V_{CC} The reverse polarity voltage protection. If the supply voltage is high enough, a series blocking diode. In other situations must be kept low blood pressure, can be employed a P Channel MOSFET (Figure 5 Shown).

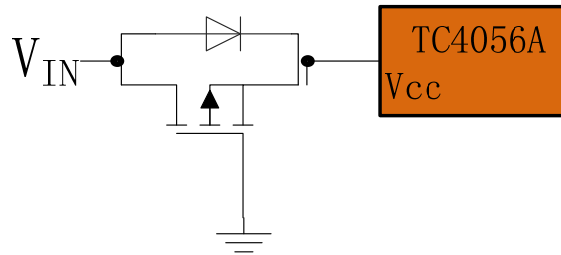

Map 5: Low-loss input reverse polarity protection

USB And AC power adapter

TC4056A Allowing an AC adapter or from a USB Port for charging. Map 6 Shows how the AC adapter and USB One example of the power input to be combined. One P Channel MOSFET (MP1) When the AC adapter is used to prevent back conducting into the USB Port, and a Schottky diode (D1) Were used to prevent USB After power 1K Loss occurs when the pull-down resistor. Generally, the ratio of the AC adapter can be provided as a current limit 500mA of USB Much of the current port. Thus, when the AC adapter is the access, can be a N Channel MOSFET (MN1) And an additional 10K Setting resistor to increase the charge current to 600mA .

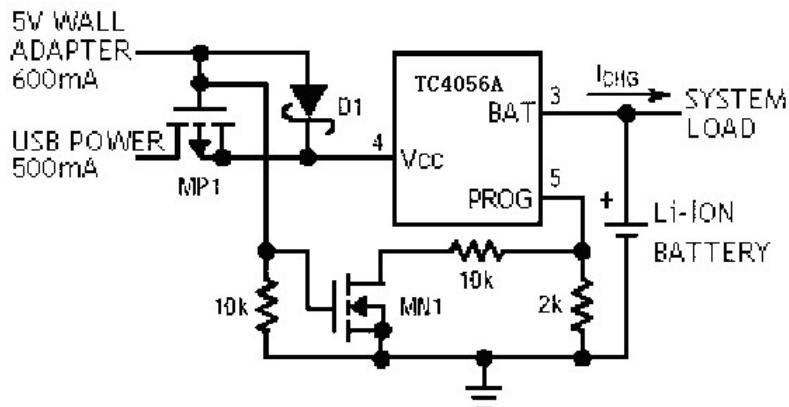

Map 6 : AC adapter USB The combined power supply

typical application

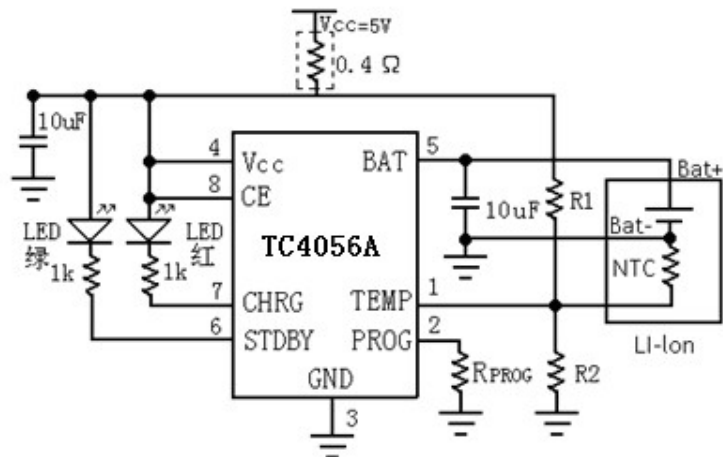

Need for battery temperature detection, battery temperature abnormality is indicated

And charging status indication application

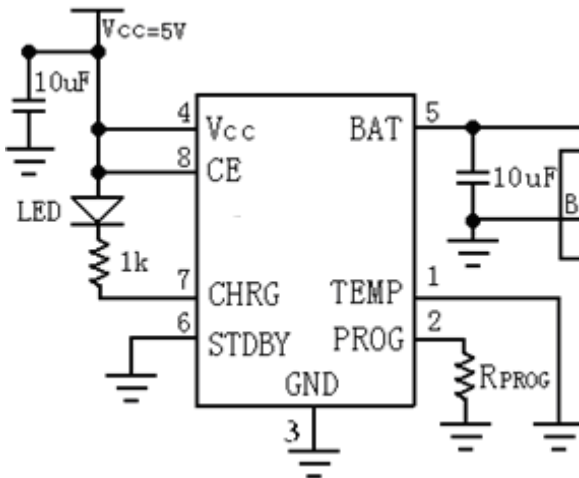

Required for status indication, and does not require

Application of battery temperature monitoring function

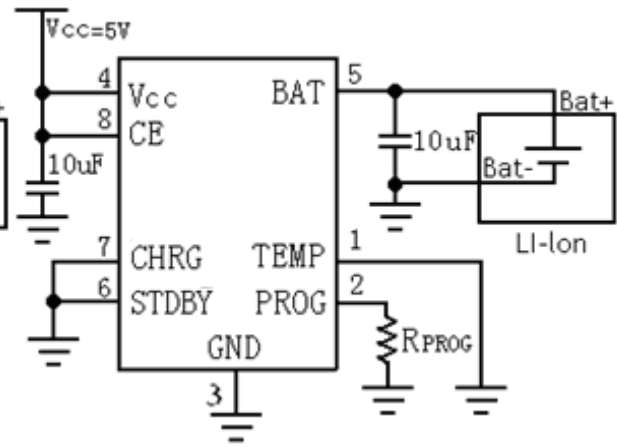

Suitable neither status indication, and does not require

Application of battery temperature monitoring function

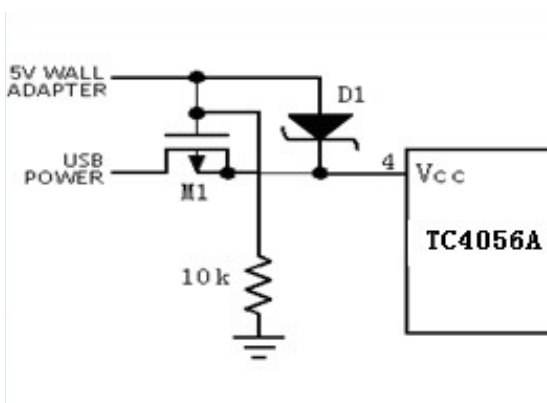

For simultaneous application USB And charging interfaces wall adapter

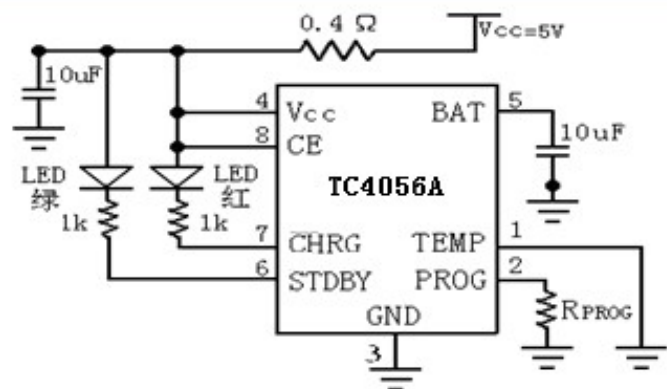

Red state of charge led Indication, the state of the charge completion

green led It indicates, increasing the dissipation power of resistance

TC4056A Cautions and DEMO Specification plate

TC4056A Caution:

- TC4056A use SOP8 / ESOP8-PP Packaging, the need to use the bottom of the heat sink and PCB Well plate welding, the bottom area need to increase the heat dissipation through holes, and a large area of the copper foil excellent heat dissipation. Multilayer PCB Plus vias sufficiently good cooling effect, the cooling effect may cause poor charging current is reduced by the temperature protection. in SOP8 / ESOP8 The back surface of the heat radiating portion with appropriate vias, also to facilitate the manual welding, (from the back through hole filling solder, reliable weld heat dissipating surface).
- TC4056A Application of large current charging (700mA Above), in order to shorten the charging time, the need to increase the heat dissipation resistor (as in FIG. R11 , R12), Resistance range 0.2 ~ 0.5Ω . Customers select the appropriate size of the resistance based on usage.
- TC4056A Applications BAT End of 10u Position close to the chip capacitor BAT End is preferred, should not be too far.
- TC4056A testing, BAT End should be connected directly to the battery, not in series ammeter, the ammeter can be connected Vcc end.
- To ensure reliable use in each case, to prevent chip damage due to voltage spikes and glitches, it is recommended BAT And each terminal connected to a power input terminal 0.1u Ceramic capacitors, and very close in the wiring TC4056A chip.

TC4056A DEMO Board circuit diagram

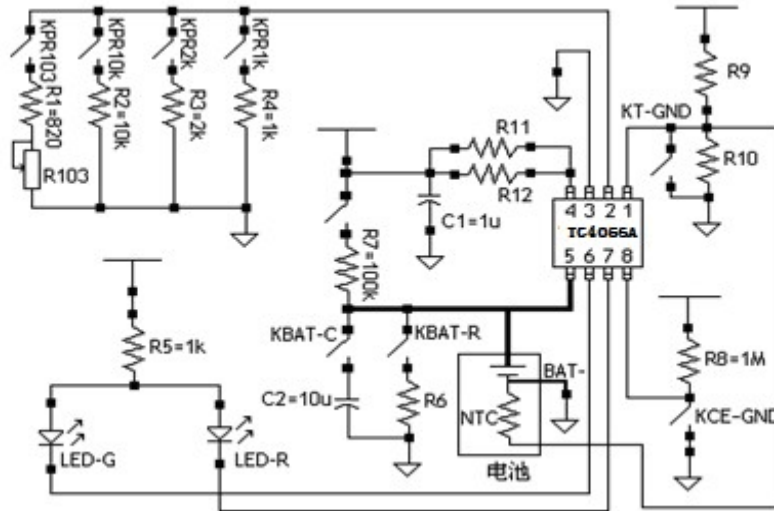

Demo Description: (Work environment: power supply voltage 5V , Ambient temperature 25 °C.)

- Charge current. (The user may select the charge current setting potentiometer desired) closed KPR1k,

RPROG = 1k 1300mA

closure KPR1.2k, RPROG = 1.2k 1000mA

closure KPR2k, RPROG = 2k 600mA

closure KPR10k, RPROG = 10k 130mA

closure KPR103, RPROG = 0.82k - 10.5k 120mA - 1300mA

- Set lights, red and green dual-lamp indication:

charging	LED status
Charging status	Red light, green light off
Battery is fully charged state	Red light off, green light
Voltage, battery temperature is too high, too low, no battery Fault status (TEMP End of the normal connection)	Red light off, green light off
BAT Termination 10u Capacitor, no battery (TEMP Grounded)	Green light, red light flashes

- Analog closed state of charge KPR10k, KBAT-C, KBAT-R , KT-GND BAT A capacitor connected to an end C2 And a resistor R6 Instead of lithium batteries, charging state analog: red light, green light off. Description: This state only the analog supply voltage less 5V ,more than the 5V Please use lithium batteries when the actual test. closure KPR10k, KBAT-C , KT-GND BAT A capacitor connected to an end C2 Instead of lithium batteries, the charging completion state analog: green light, red light flashes. Note: Due to the use of 10uF Capacitance C2 Instead of a full state lithium analog, the capacitor discharges slowly filled up when the capacitor voltage becomes a threshold voltage recharging 4.05V When automatically recharged, periodically flashes the red light can be seen.
- Analog charging end BAT Closing the terminal voltage KPR10k, KBAT-C, KBAT-R , KT-GND measuring BAT Voltage. It is the end of the charging voltage $4.2V \pm 1.5\%$.

- If the customer needs to monitor the battery temperature, disconnect KT-GND ,connection TC4056A of TEMP end(1 Feet, has been reserved connection holes) side to the lithium battery temperature monitoring, according to the actual situation from the client R9, R10 Size and install it. This function if not needed, the closure KT-GND It can be.
- CE Before it can end. Closing the switch KCE-GND , CE End down to a low level, to stop charging the chip; open KCE-GND , Normal charging chip.
- Some customers in the application BAT Without wishing to flashing red light, the closed end when no lithium KBATUP ,will BAT End with 100k Resistor is connected to the Vdd , Green light, may be used to indicate the standby state, does not affect the normal use charge.
- Lithium battery

The lithium battery cathode connected to the chip BAT End of the negative electrode is grounded. Connect the required temperature monitoring function TEMP end(1 Foot), otherwise closed KT-GND . And sets the charging current required indicator, OFF KBATR , KCE-GND To begin charging.

Mobile power scheme (software 5V / 1A)

Circuit diagram

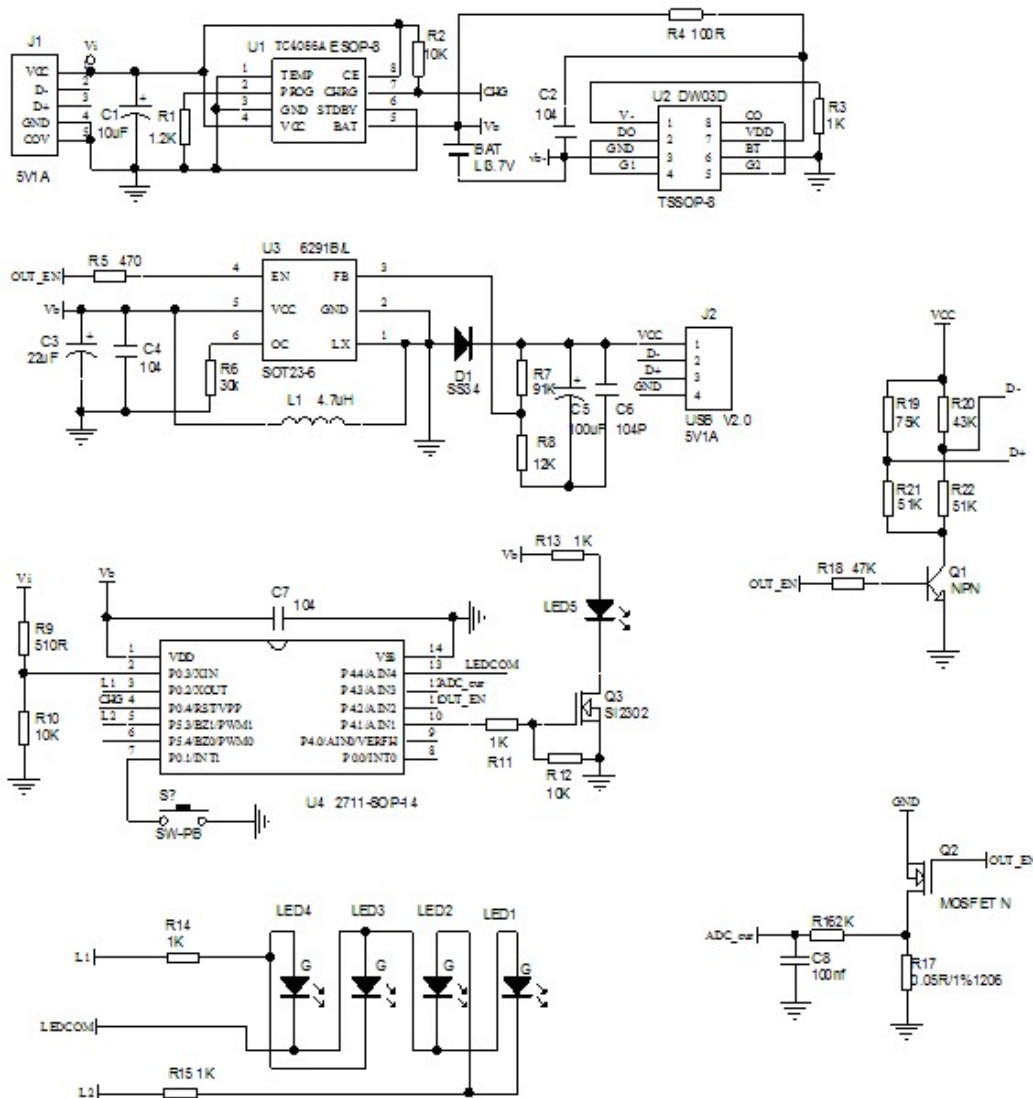

Package Description

ESOP-8 Package

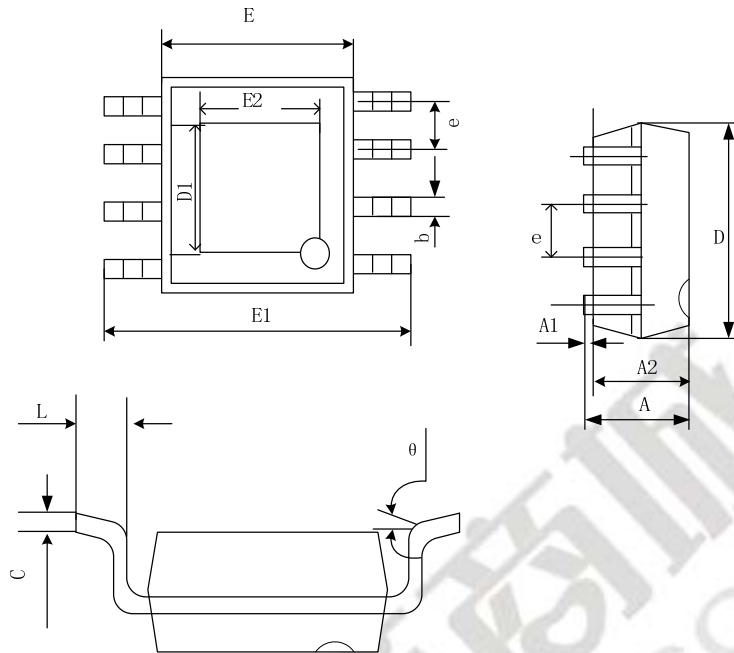

character	Unit = mm		Unit = inch	
	Minimum	Maximum	Minimum	Maximum
A	1.350	1.750	0.053	0.069
A1	0.050	0.150	0.004	0.010
A2	1.350	1.550	0.053	0.061
b	0.330	0.510	0.013	0.020
C	0.170	0.250	0.006	0.010
D	4.700	5.100	0.185	0.200
D1	3.202	3.402	0.126	0.134
E	3.800	4.000	0.150	0.157
E1	5.800	6.200	0.228	0.244
E2	2.313	2.513	0.091	0.099
e	1.270 (BSC)		0.050 (BSC)	
L	0.400	1.270	0.016	0.050
θ	0°	8	0°	8

DIP-8

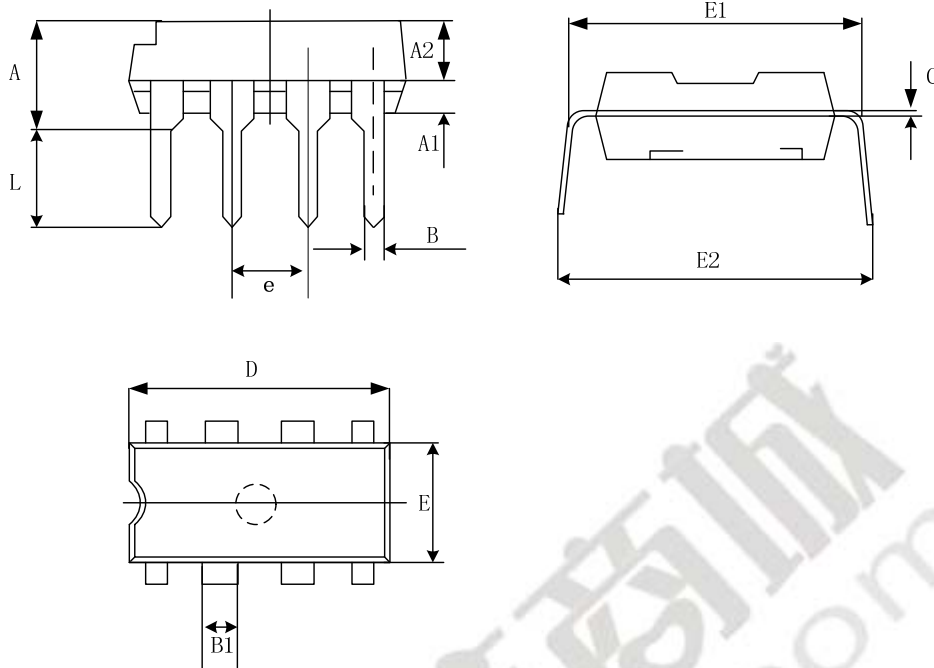

character	Unit = mm		Unit = inch	
	Least	maximum	Least	maximum
A	3.710	4.310	0.146	0.170
A1	0.500		0.019	
A2	3.200	3.600	0.126	0.142
00B	0.350	0.620	0.0138	0.024
B1	1.524 (BSC0)		0.060 (BSC0)	
C	0.204	0.360	0.08	0.014
D	9.000	9.500	0.354	0.374
E	6.200	6.600	0.244	0.260
E1	7.320	7.920	0.288	0.312
e	2.540 (BSC)		0.100 (BSC)	
L	3.000	3.600	0.118	0.142
E2	8.200	9.000	0.323	0.354